

QOS Reliability and Improvement for Congestion Probability Routing in ATM Networks

P. Rajan and Dr. Arul Lawrence Selvakumar

¹Research Scholar, Bharathiyar University, Coimbatore-641046

²Prof. and Head, Dept. of CSE, Rajiv Gandhi Institute of Technology

ABSTRACT: *The other primitives for switch management and control are borrowed heavily from the specified protocol. They include priority for switch configuration port and switch management VP management and permanent measurement. The protocol was implemented and integrated with the OPNET platform. Without going into specifics of the protocol we describe its design principles and show how it has affected in the protocol. Traditional connection switches include an embedded processor that implements both the switch control and network signaling. The objective of CAC is to keep the network load moderate to achieve a performance objective associated with QOS. Cell loss ratio a key QOS parameter in ATM networks is essential for proper network resources dimensioning, congestion control , bandwidth allocation and routing.*

KEYWORDS: QOS, Reliability, Improvement, Congestion Probability

INTRODUCTION

The objective of this maximum of network resources utilization and minimum of their cost. Transmission bandwidth buffer space and the network resources are maintained. Fairness which is interpreted as fair access to network resources for all user. This criteria is when a CBP equalization is achieved.

Receiving one of a large number of measurements or other assessment of conditions existing in the control system. Processing all these input according to human based fuzzy if then rules which can be expressed in plain language words in combination with traditional non fuzzy processing. Averaging and weighting the result output from all the individual rules into single output decision or signal which decide what to do or tells the controlled system what to do. Buffer overflow[2] occurs on multiplexed channels as a result of network congestion thereby resulting in the loss data packets which grossly affect the QOS of the transmitting traffic.

Another problems in which an ATM technical request connection admission and supplies the CAC with only a limited amount of information concerning its bandwidth requirements. The absence of detailed detailed in the operation of CAC[1] imply that calls which could be supported or otherwise refused. User do not have to specify their traffic parameter precisely from the call establishment and the output control is a smooth control function despite a wide range of input variations. Using the user defined rules the control system can be modified easily by changing or including the appropriate rules affect the change.

The connection involves a single sender and a single receiver. The multipoint connection can involves multiple sender and/or receiver. In general the notation of multi processor refers to connection that involve a group of user with more than two members.

RELATED WORKS

Monitoring the CLR reference under in service condition and verify that the performance mass the QOS requirements. Identify the location and cases for the CLR reference degradation without affecting the customer. Conductive reactive and perspective maintenance by continuously investigating and performance trends. Preserve compatibility with current socket based application interface so that existing application can run unchanged. Provide extentions to the interface for specification and negotiation of QOS parameters[4]. Separate control and data path. This is particularly useful for data path optimizations in many continuous media applications.

Simplified call admission control since traffic within each VP is isolated from traffic in other VP. Strong end to end guarantees on cell delay and cell loss probability can be provided. Fairness consists of network accessibility can be easily implemented by appropriate assignment of traffic to VP. The rule base hold the knowledge inn the form of a set of rules of how best to control the system. The interference mechanism evaluate which control rules are relevant at the current time and then decides what the input to the system should be. The fuzzification interface too simplify and modify the output so that they can be interpreted and compared to the rules in the rule base. The defuzzification interface connect the conclusion reached by the interference mechanism into the input to the system.

Simulation Results

It is clear that because of the computational complexity these algorithm are practical for solving real time problems. However these are several polynomial situations which can find good solution to solve this type of problem efficiency. Moreover it can generate that the cost of the solution is within a factor of two items the cost of the optimal solution. ATM scenario where traffic is differentiated in ATM switch for further submitting to calculate established connections inside NS available in the ATM i.e. CBR. The IP router performs simple packet [6] for forwarding only without applying any QOS features. It can be treated as completely transparent.

Where traffic is differentiated in IP router for further submitting to earlier established connection inside NS available in the input QOS. A single ATM connection is designed for whole IP traffic hence the ATM is transparent. The ATM fiber optic switch i.e. used to link the ATM network. ATM encounters that convert the electrical signal of the optical signals in order to send it the ATM fiber switch. Monitor the system is used to display the video streaming received from the optical signal to electronically signal in the ATM decoder. The ATM network should be extended to include more real time traffic on it used to see what happens with quality measurements values and the traffic conjunction issues.

The average rate of referred to the TCP layer by the applications at the source. It is calculated by dividing the tool bits submitted by the simulation time. The total number of bits forwarded to the applications layer by the TCP layer at the destination. The end to end delay of packet received by the TCP layer. It is measured by the time an application data packet is tent to the source TCP layer to the time it is received by the TCP layer at the destination.

The approximate MPOA configuration and device discovery are assumed. Intra subnet is taken care by LAN emulation and the correctness of emulated LAN is assumed. Routing table in each router i.e. stable during the simulation period[3]. Control VCs between ingress MPC and MPS

are already established. Translations between MPOA resolution messages and NHRP resolution messages are always correct. MPOA resolution reply for each MPOA resolution request is guaranteed. Thus the MPOA destroy mechanism is not simulated. MPS/NHS in our simulation never fail. Thus the keep alive protocol is not simulated. Each Egress MPC always has been enough resumes to maintain the cache entry and receive a new shortcut.

Fig 1: Virtual Router for MPOA

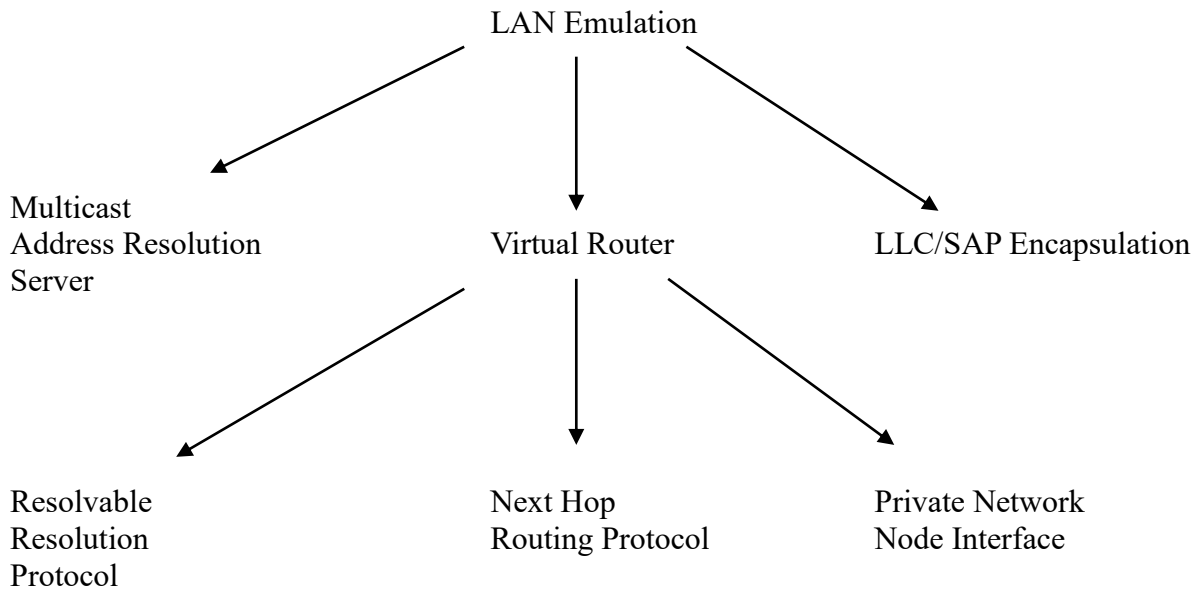

Fig 2: Switch Forwarding Procedure

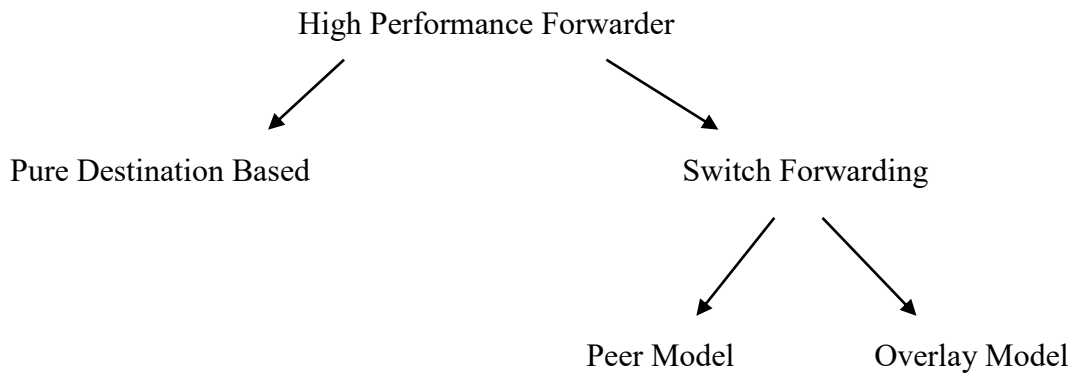

Fig 3: Multicast Routing

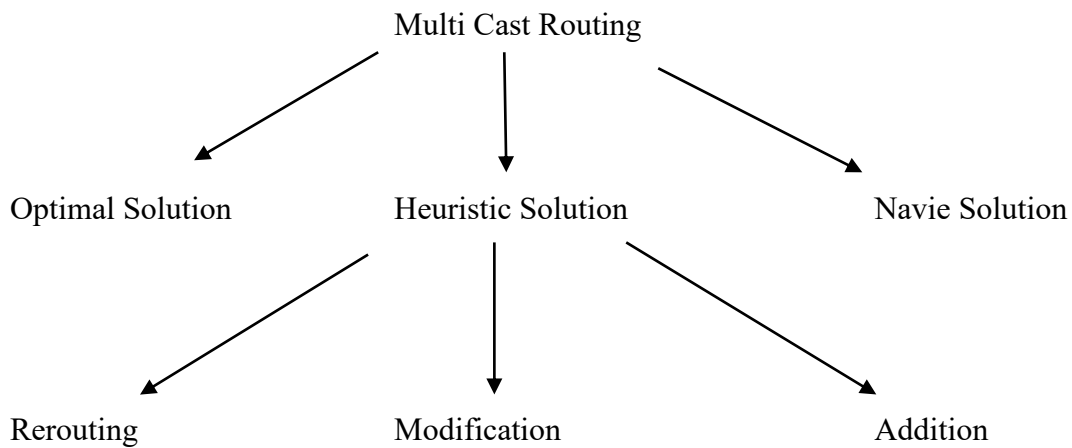

Fig 4: Multi Layer Architecture

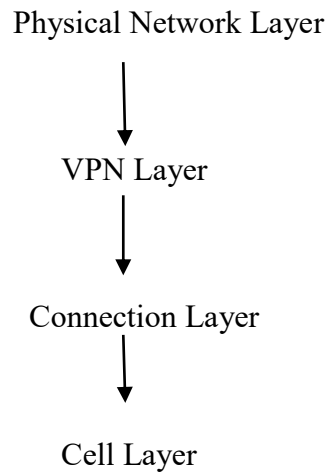

Table 1: Throughput table

S/E	16	20	24	28	32
16	15	13	0	0	0
20	15	14	15	14	15
24	17	16	16	16	17
28	16	17	17	16	18
32	14	18	18	19	19

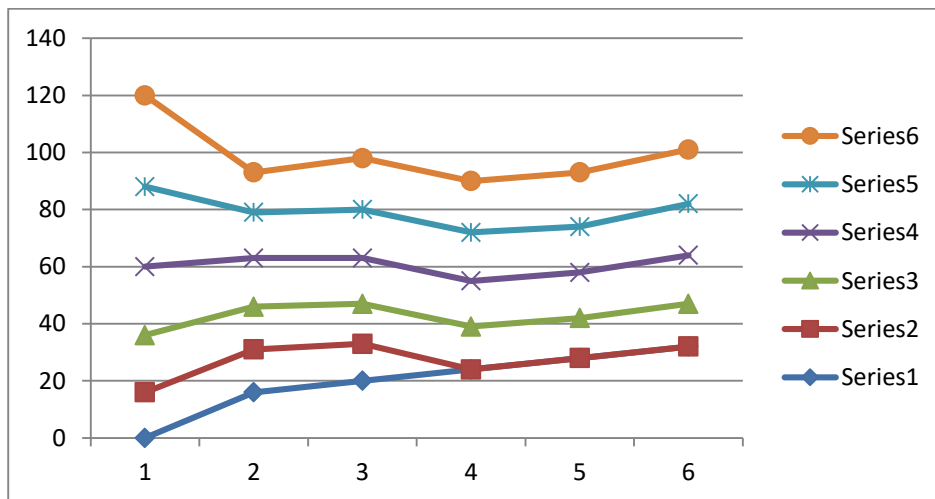
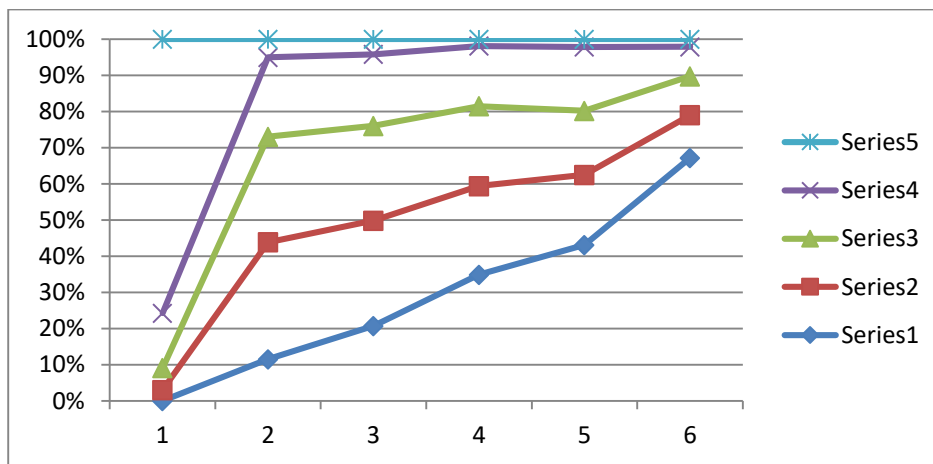

Table 2: Different frame nodes

Frame	1	2	5	25
32	90	81	61	14
64	90	81	61	13
128	90	81	61	7
200	90	82	82	10
512	90	82	62	16



Performance Results

Performance result was carried out to determine the BER important latency and work load characteristics. A network analyzer was used to generate monitor ATM traffic [5]. Test was carried out to find various error parameters and the latency. Channel simulator used to emulate the radio link character in the lab settings. Two set up were used to bring out the performance improvement and latency issues. The design has been successfully developed and implemented and evaluated for its performance. The result matched with in the theoretical analysis.

The over all concern is to avoid network congestion which ultimately result to reduced QOS for the cells transmitted. Cells that we have PCR higher than the available bandwidth should be rejected. In our result presents a better utilization of the network resources depicted by dramatic reduction in the conversion for available resources. With a true representation of bursty environment in the simulation scenario the new implementation was able to adjust to the on and off nature of the traffic parameter.

The simulated result as pin point that with the consideration unsolicited burst which actually result into network traffic congestion where properly accumulated. This is equal to the fact that admission process was properly guided by taking into consideration the probability admitted calls being bursty during the case of transmission. At the point where the bandwidth is on the average level[7], the MBS has to be low for the calls to be accepted. So also when the bandwidth is low then the MBS has to be lower than the bandwidth for calls to be accepted on the network.

Our scheme not only monitor this but also ensure strict compliance to the hitted to negotiated QOS as much as possible. We are able to create a balance in the effect of burst which is cell loss and the over all admitted number of cells. The conventional method is concerned with admitting calls based on their PCR and SCR only. This approach[8] does not give consideration for bursty traffic where the needed bandwidth varies during transmission. So in situation where this available bandwidth to transmit a call initially based on its SCR getting into less space should it become bursty then there is high potential for network congestion.

CONCLUSION

The result was a most robust approach capable of sustaining and determine and managing as ATM network by generating user negotiated QOS at the point and admission reduction in cell loss rate if not eliminating it and more importantly providing platform for improved mode of utilizing the messages network resources. The investigation of resource sharing among services and service scheduling at each ATM switch. The incorporate of routing as an optimization component into the provisioning approach. The comparison of the approach development here with the service provisioning approach using stochastic network models. LAN emulation provides a simple and efficient way to introduce ATM into means by ensuring that the raw bandwidth of ATM can be used to alleviate congestion and traffic problems on existing LAN.

Acronyms

CIR – COMMITTED INFORMATION RATE
FRS – FRAME RELAY SERVICE
HLR – HOME LOCATION REGISTER
IWR – INTER NETWORKING FUNCTION
MIB – MANAGEMENT INFORMATION BASE
MSC – MBILE SWITCH CONNECTION
NCP – NETWORK CALL PROCESSOR
PCN – PERSONAL COMMUNICATION NETWORK
PLP – PACKET LEVEL PROCEDURE
PVC – PERMENANT VIRTUAL CONNECTION
RSS – RADIO SIGNAL STRENGTH
SAR – SEGMENTATION AND RE ASSEMBLY
SDU – SERVICE DATA UNIT
SVC – SWITCHED VIRTUAL CONNECTION
VCT – VIRTUAL CONNECTION TREE
VLR – VISITOR LOCATION REGISTER
WRC – WITH RESERVED CHANNEL
VCC – VIRTUAL CHANNEL CONNECTION

REFERENCES

- An ATM Switch Control Interface for QOS and Reliability by Rahul Gang.
Analysis of VBR Traffic on ATM Network Using Simulation Model , Rohini Sharma , Feb 2015.
- Congestion Probability Routing in Virtual Path ATM Networks by Fabragat Gesa, 2010.
- Implementation of IPV6 TOS over ATM Network by Ricky NG
- Switching Negotiated QOS in CAC for ATM Networks by GA Aderounmu, 2008.
- Traffic Control Through in Service Monitoring for Improvements in ATM Networks by Yaw Chang Chen, Dec 1999.