

**GOVERNMENT-INDUSTRY POLICY ON INVENTORY MANAGEMENT
TECHNOLOGY FOR ENHANCED PRODUCTIVITY AND GDP GROWTH RATE
IN NIGERIA**

Odigbo Benedict Ejikeme¹, Maduagwu Nneka² and Sunday Uduak Udo¹

¹Department of Marketing, University of Calabar, Nigeria.

²Department of Marketing, Faculty of Management Sciences, Enugu State University of
Science & Technology, Enugu State - Nigeria.

ABSTRACT: *Today's development is not possible without advanced technology. In the area of manufacturing, technology is quickly changing the way in which stock is handled and controlled for enhanced productivity. Sophisticated information gathering systems can track items from the purchase order to the final customer on the sales chain. Automation can dramatically impact all phases of inventory management, including counting, monitoring, recording and retrieval of items, storage location; recording changes to inventory; and anticipating inventory needs, including inventory handling requirements. The manufacturing and retail industries, worldwide, have created standards to take advantage of new technologies and computerized systems such as the Radio Frequency Identification (RFID), barcodes, vending machines, warehouse technology management system, etc. All these provide accurate inventory information on a constant basis thus, enhance organisation's productivity and increase its competitive edge over companies that are slow to take advantage of these new technologies. Finding the position of Nigerian manufacturing firms in this equation was the major focus of the study. Results indicated poor performance. Based on that, a case for government-industry policy framework that will make it mandatory for manufacturers in Nigeria to use technology-based inventory management system for enhanced productivity and GDP growth was made by the authors.*

KEYWORDS: Technology, Industry Policy, Inventory Management, Productivity, GDP Growth.

INTRODUCTION

Inventory management is a backbone for almost all enterprise, to define growth, success or survival of a business (Mathaba et al, 2011). Investment in inventory represents the major assets of most industrial and commercial organizations (Eteng, 2008), and managing assets of all kinds can be viewed as an inventory problem (Koumanakos, 2008). Poor inventory management leads to increased cost, risks of obsolescence, pilferage, damages and inventory stock out which could subsequently lead to brand switching, loss of customers and low sales volume (Ebitu, 2014). This, therefore, poses the challenge of knowing the exact amount of inventory to keep at a given time (Singh & Pandey, 2009).

The fact is, participants in the supply chain and manufacturing process must produce and provide timely, accurate information, about products quantity and location, otherwise, productivity and profitability of the company will suffer (A Zebra Technology White Paper, 2013) and achieving supply chain visibility – that is, being able to know where an item is within the supply chain at any point in time – is made possible through the use of modern inventory management technology. Manufacturing firms worldwide have shifted from the

problem-bound paper-based inventory management system to technology-based system and have created standards to advantage of new inventory management technologies such as the RFID, Barcodes, Warehouse Management System, Vending Machine, etc. Such technologies guarantee accurate and timely inventory information on a constant basis and thus, enhance organization's productivity and increase its competitive edge over competitors who are slow to take advantage of these new technologies.

But this is not the case with Nigeria Manufacturing firms. Therefore, the study which is a critical analysis of the Nigeria Manufacturing firms reveals the real situation of the manufacturing firms – low productivity and insignificant contribution to the GDP growth rate – and calls on government intervention in the form of policy that mandate the use of technology in controlling inventory in the Manufacturing companies in Nigeria.

Statement of Problem

Effective and competent inventory management is vital to organization's success; its growth and profitability. Manual inventory management is labour intensive, costly and error prone. In addition, scheduled scanning or manual method cannot ensure that the inventory remains up to date, due to oversights, errors and internal shrinkage. Inventory management technologies guarantee accurate and timely inventory information on a constant basis thus, enhance organization's productivity and increase its competitive edge over competitors who are slow to take advantage of these new technologies. Sadly, some manufacturing firms in Nigeria are among firms who are slow to take advantage of modern inventory technologies. They still struggle with the problem-bound paper-based inventory management system and as a result, they experienced delayed order fulfillment and prolonged lead time due to manual information processing and communication with suppliers. They also experienced theft of spare parts, tools, operating supplies etc., because the workers are allowed to take these items at will without proper documentation. Their inefficient or poorly-managed logistics operations increased their overheads and reduced customer satisfaction, posing a significant threat to their profitability as a result of low productivity. All these necessitated the drive for this study, ascertain the place of Nigerian manufacturing firms in the adoption of modern inventory technologies in their operations.

Study Objectives

The specific objectives of the study included:

- i. To analyse the extent of application of modern inventory technology by Nigerian manufacturing firms.
- ii. To ascertain the effect of level of application of modern inventory technology by Nigerian manufacturing firms on their corporate performance.
- iii. To determine the effect of inventory technology adoption levels of the Nigerian manufacturing firms on employment generation and GDP contributions.

Research Questions

The following research questions guided the study:

- i. Do majority of Nigerian manufacturing firms significantly apply modern inventory technologies in their operations?
- ii. Does the level of application of modern inventory technologies by Nigerian manufacturing firms have significant positive effect on their corporate performance?
- iii. Does the inventory technology adoptions' level of the Nigerian manufacturing firms have significant positive effect on employment generation and GDP contributions of Nigerian manufacturing firms?

Research Hypotheses

The following null-hypotheses were tested in the study:

- i. Majority of Nigerian manufacturing firms do not significantly apply modern inventory technologies in their operations.
- ii. The level of application of modern inventory technologies by Nigerian manufacturing firms has no significant positive effect on their corporate performance.
- iii. The inventory technology adoption levels of the Nigerian manufacturing firms have no significant positive effect on their employment generation and GDP contributions to the economy.

METHODOLOGY

The study adopted a combination of critical analysis and survey design. The secondary data were sourced from available statistical records from official governmental agencies and qualitatively analysed. The primary data were sourced from select manufacturing companies in Cross Rivers State, Nigeria, and quantitatively analysed with the statistical tool of criterion mean. According to Eleje (2009), a critical analysis is subjective writing because it expresses the writer's opinion or evaluation of a subject matter. Grave (2006) also notes that to do a critical analysis effectively, the rules to follow are: Identify the focus of the assignment, identify your own point of view, consider how you'll persuade other people of your point of view, find the proof, engage in the debate, and structure the argument. On its own part, the University of Washington Tacoma Learning Centre (2014), says for a critical analysis to be valid it must offer a solution to the problem(s) it raised and it must be plausible.

REVIEW OF RELATED LITERATURE

Theoretical Construct

The theoretical construct of the study revolves around one important inventory management technology known as the Radio frequency Identification Theory of operation.

Radio Frequency Identification (RFID) Theory of Operation

RFID is an automatic identification technology that relies on radio frequency (RF) waves to read encoded digital data (Zebra technologies white paper, 2013). RFID tags come in a broad range of shapes and sizes depending on the frequency range and antenna design. As a general rule, the decision to use one tag over another depends on several factors including physical environment, required read range, and even the physical properties of the material that one is tagging (Brown, 2013, Nikitin, 2008, Mickle 2007).

Note that there are actually three RFID tag types: active, passive, and semi-active (Brown, 2013). Active RFID technology uses fixed tag readers assigned throughout a warehouse. Anytime an item with an RFID tag passes the reader, the movement of the item is recorded in the inventory management software. Active systems work best in environments that require real-time inventory tracking or where inventory security problems exist (Hamlett, 2006). Because active and semi-active tags use an onboard power source to power the tag response, they are typically capable of much longer read ranges (Brown, 2013). RFID technology has a reading range of up to 300 feet using active technology, and it greatly increases the accuracy of moving inventory around a warehouse (Hamlett, 2006). Passive tags, on the other hand, are actually powered by electromagnetic energy from an interrogator's command and have a reading range of up to 40 feet. This technique significantly lowers the cost of the tag, but it also limits the read range and creates significant – but interesting – design challenges (Hamlett, 2006; Brown, 2013).

Tag-to-Reader Interaction: The Inventory Round

An RFID system consists of a tag reader (also called the interrogator) and a tag. All communication between the tag and reader occurs completely through a wireless link that is sometimes called an air interface. Through a sequence of commands sent and received between both devices (called the inventory round), an RFID reader can identify the electronic product code (EPC) of an RFID tag. For passive tags, the basic idea is that the interrogator initiates an interrogation round with a query command. The query command essentially “wakes up” the tag, which responds with the appropriate information. Figure 1 shows a basic block diagram of the tag/reader system.

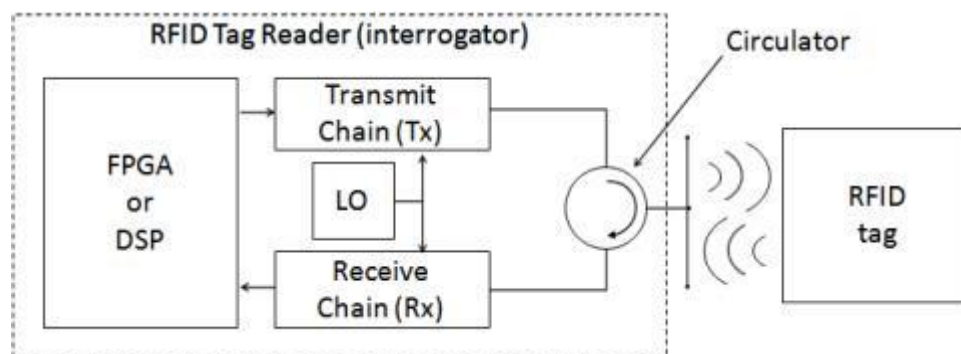

Figure 1: Block Diagram of a Typical RFID Tag/Reader System

Note, from Figure 1 that many RFID readers and measurement systems actually use a three-port RF component called a circulator that gives both transmit and receive front ends the ability to use the same antenna. Note that with many RFID, standards, timing information between transmit and receive commands is defined by strict guidelines. In fact, a sort of

“handshaking” is required between the tag and reader to complete an interrogation round. This actually creates a unique test challenge because the instrumentation must be capable of the same behavior. On an interrogator, an embedded processor is required to decode and generate commands within a tight timing interval. As discussed in a later section, this design is quite similar to Field-Programmable Gate Array (FPGA)-enabled RFID measurement systems, which use similar embedded processing to fully emulate either a tag or a reader (Brown, 2013, Nikitin, 2008, Mickle 2007).

CONCEPTUAL FRAMEWORK

Inventory Control System

An inventory control system is a system that encompasses all aspects of managing a company's inventories; purchasing, shipping, receiving, tracking, warehousing and storage, turnover, and reordering. In different firms the activities associated with each of these areas may not be strictly contained within separate subsystems, but these functions must be performed in sequence in order to have a well-run inventory control system. Computerized inventory control systems make it possible to integrate the various functional subsystems that are a part of the inventory management into a single cohesive system (Udo, 1993; Harry, 2005).

New technologies have greatly improved the tools used to manage inventories. Powerful computer systems that are linked into networks are now able to receive information from handheld devices. The wireless handheld devices scan bar codes on inventory items and send data to a tracking database in real time. The increased efficiency of inventory systems over the past 25 years made some things possible that would have been impossible in earlier times, like the popular just-in-time manufacturing system. Automation can dramatically impact all phases of inventory management, including counting and monitoring of inventory items; recording and retrieval of item storage location; recording changes to inventory; and anticipating inventory needs, including inventory handling requirements. This is true even of stand-alone systems that are not integrated with other areas of the business, but many analysts indicate that productivity—and hence profitability—gains that are garnered through use of automated systems can be further increased when a business integrates its inventory control systems with other systems such as accounting and sales to better control inventory levels (Safizadeh, et al, 1997; Udo, 1993).

Many companies still are not taking advantage of technology to the fullest, the ones that are using inventory control software can easily forget how hard it was to manage inventory without it. The inventory control system enables firm or an organization to strike a balance on the various costs, so as to minimize total cost and hence maximum profit. It has proper record keeping and good stock monitoring scheme, knowledgeable storekeeper and assistance clerk. It gives assurance that the goods produced in good condition can meet specification. It saves time and provides easy access to stock status or data. These inventory control software include, but not limited to RFID, barcode, warehouse management and vending machine software (Safizadeh, et al, 1997; Udo, 1993; Harry, 2005).

Types of Inventory Control Systems

Properly managing inventory requires a system of some sort. It does not matter if the system consists of writing inventory levels on the back of an envelope or using the most sophisticated radio frequency identification system. As the old saying goes, “there are many ways to skin a cat”, the different types of inventory control systems all have pros and cons, choosing the right one boils down to which system holds the most value for the company (Hamlett, 2006; Rubin, 2007). Basically, two types of inventory control systems are discussed, namely:

- Physical inventory system
- Perpetual inventory system

Manual/Physical Inventory Management System

Physical/manual inventory system is one where stock is visually inspected or actually counted to determine the quantity on hand. A physical inventory is conducted on a periodic basis, usually once a year, to calculate the value of ending inventory (Hamlett, 2006; Farese et al, 1997). Physical inventory management involves creating a physical inventory document, entering the physical inventory count and posting inventory differences (help.sap, 2014). This system allows small business owners to manage inventory with little investment in systems or training (Hamlett, 2006).

In most small businesses, the owner manually counts products and materials that are on hand and enters the values in the spreadsheet and also enters expected usage based on existing orders at the start of each week. Using the appropriate spreadsheet formulas, the owner can determine if he has enough materials for the week or if purchases should be made. However, the physical or manual inventory system requires more time and paperwork (Farese et al, 1997). And maintaining data integrity is a major downside to physical or manual inventory management as a single data entry or formula error can cause major inaccuracies in the data output (Lysons, 2001; Hamlett, 2006).

Perpetual Inventory System

This system tracks the number of items in inventory on a constant basis. It tracks all new items purchased and returned, as well as sales of current stock (Farese, et al 1997). An up-to-date inventory is maintained for purchases and returns of merchandise, sales and sales return, sales allowances and transfers to other stores and departments. Perpetual inventory systems cover continuous intake of stock and up-to-date financial records. It helps keep constant track of incoming and outgoing materials, work-in-progress and the day-to-day sales of goods. Check sales and stock records against each other frequently for accuracy. With perpetual inventory, a business keeps tracks of sales as they occur (Farese, et al, 1997). Perpetual inventory has two main benefits. It improves record-keeping practices, making it simple to calculate cost of goods sold in a certain period. Secondly, it allows businesses to see accurate inventory at a given moment, making it easier to know when to order more. This higher degree of control can make companies more dynamic, and helps keep up with customer demand. Its major disadvantage is the upfront cost of implementation (Griffin, 2015).

Inventory Management Technology

A solid inventory tracking system has significant financial benefits. With technology-based inventory control, it is easier to track products inflows and outflows as well as stock balance (Murphy, 2010). The right mix of technology can help with the layout of a warehouse as well as the efficient flow of its people and products (Christian, 2013). Technologies can lend an almost scientific approach to logistics operations planning (Christian, 2013). Inventory tracking technology results in a better bottom line and a more profitable business. Effective inventory management – augmented by technology – help the businesses keep track of inventory and track items through the products' sales cycle (Murphy, 2010).

The Benefits of Using Inventory Management Technology in Manufacturing Companies in Nigeria

The importance of inventory management technology cannot be over-emphasized. Electronic inventory management is error free, efficient, effective, flexible and accurate. It improves labor productivity and reduces labour costs by eliminating manual steps. It also improves customer satisfaction through timely and accurate shipping (Zebra Technologies white paper, 2013). For example, the barcodes technology is an effective tool for producing greater than 99.9% data accuracy and is a far superior method of entering data into a host system than key entry, or, worse yet, manual record keeping with pencils and forms (Zebra Technology white paper, 2013). Radio Frequency Identification (RFID) technology enables the reading of products in real time and eliminates problems like counterfeiting, replenishment of stock, and product misplacement without requiring human intervention, and the information is sent directly to the back-end system for later retrieval (Mathaba et al, 2011). Vending machine technology is capable of dispensing products following money insert, products select, products dispense, and servicing, routine (Monga & Singh, 2012) and hence, keeps records of both the amount of sales in terms of money and the quantity of products dispensed, as well as calls for servicing when products are exhausted. Manufacturing companies use vending machine to dispense parts to the workers and therefore, monitor their usage. Goksoy et al, (2013) shows that the warehouse management technology tracks products during the production process and is closely related with manufacturing system management.

Generally, inventory control systems work in real time using technology to transmit information to a central computer system as inventory is monitored and as transactions occur to ensure an organized management system and generate detail-oriented records and reports that cover all aspects of the business (Harry, 2005).

The Advantages of Using Technology-Based Inventory Management System to Boost Nigeria's Economy

The importance of technology-based inventory management cannot be over-emphasized. While paper-based or manual inventory management system is labour-intensive, time-consuming and error-prone, technology-based inventory management system is cost-effective, efficient and accurate. The following are summarized advantages of using an electronic-based inventory management system.

1. Technology enables the reading of products in real time and eliminates problems like counterfeiting, replenishment of stock, and product misplacement without requiring human intervention..." (Mathaba et al, 2011). Technology-based inventory management transmit information to a central computer system as inventory is

monitored and as transactions occur to ensure an organized management system and generate detail-oriented records and report that cover all aspects of the business (Harris 2005).

2. With technology-based inventory control, it is easier to track products inflows and outflows as well as stock balance (Murphy, 2010).
3. The right mix of technology can help with the layout of a warehouse as well as the efficient flow of its people and products (Christian, 2013). Technologies can lend an almost scientific approach to logistics operations planning (Christian, 2013).
4. Inventory tracking technology results in a better bottom line and a more profitable business. Effective inventory management – augmented by technology – help the businesses keep track of inventory and track items through the products' sales cycle (Murphy, 2010).
5. It promotes known inventory and item location at all times, reducing product search time, improving inventory stocks, and enhancing manufacturing process control.
6. It also helps to enhance compliance, improve work-in process (WIP), productivity, and reduce finished goods cost.
7. Enables real-time monitoring of production, order fulfilment, and distribution process and their level of efficiency.
8. Aids in moving products profitably and quickly to meet demand and reduce inventory costs and reduce labour costs by eliminating manual steps.
9. Increases order and shipping accuracy. Helps ensure that order ship complete, error-free, and on time, thus improving customer satisfaction.
10. Promote real-time data capture via warehouse management system (WMS) and enterprise resource planning (ERP) systems.

DATA PRESENTATION QUALITATIVE ANALYSIS AND THE IMPLICATIONS

Statistical Record of Manufacturing Industry's Performance

The history of industrial development in Nigeria is a classic illustration of how a nation could neglect a vital sector through policy inconsistencies and distractions attributable to the discovery of oil (Adeola, 2005). In 1960, the manufacturing industry made a modest contribution of 4.8% to the GDP and later increased to 7.2% in 1970 and to 7.4% in 1975. But in 1980, it declined to 5.4% and then surged to a record high of 10.7% in 1985. By 1990, the share of manufacturing in GDP gradually dropped to 8.1%, and further to 7.9% in 1992, 6.7% in 1995, and stood at 6.3% in 1997. As at 2001, it further declined to 3.4% from 6.2% in 2000. It increased to 4.23% in 2013 (CBN, 2013) which is less than what it was in 1960.

Research Objective 3: To determine the effect of inventory technology adoption levels of the Nigerian manufacturing firms on employment generation and GDP contributions.

Manufacturing Industry's Contributions To Nigeria's GDP Nigeria (2000 – 2013) and Comparative Analysis with Other Nations

Currently, Nigeria's manufacturing sector's share in the GDP remains minuscule (CBN, 2013) compared to the strong manufacturing sectors in other emerging economies, where structural change has already occurred. For instance, the Nigeria Manufacturing sub-sector is responsible for only about 10% of total GDP annually. A comparative analysis with other nations show that the manufacturing sector contributes 20% of GDP in Brazil, 34% in China, 30% in Malaysia, 34% in Thailand and 28% in Indonesia (Ogbu, 2012).

It is still a far cry when we compare it with some other countries like South Africa (16%), Singapore (24%), Egypt (15%), Brazil (20%), China (30.4%), (30%) in Malaysia, 34% in Thailand and 28% in Indonesia (Onuoha, 2013; Ogbu, 2012). All these go to show the low level of indigenous technology in Nigeria. A CBN report buttressed the point that technology is the greatest obstacle constraining productivity in Nigeria's manufacturing sector as development in technology and innovation are the primary forces of industrialization today (Ayeni, 2013).

Manufacturing Industry's Contributions to Employment in Nigeria

In terms of employment generation, manufacturing activities account for about 12 per cent of the labour force in the formal sector of the nation's economy. This is why manufacturing statistics are relevant indices of the economic performance of a nation says the National Bureau of Statistics (NBS, 2012).

The implication of this is that Nigeria has no effective industrial policy that promotes manufacturing; at least not in the sense of policy which provides practical solutions to the difficulties encountered by incipient entrepreneurs or emerging manufacturing firms. Therefore, this paper sees fit the formulation of government-industry policy that will make it mandatory for manufacturers in Nigeria to use technology-based inventory management system for enhanced productivity and GDP growth rate in Nigeria, noting that in modern world, manufacturing sector is a basis for determining a nation's economic efficiency (Amakom, 2012).

Primary Data Presentation and Analysis

A total of 220 copies of the structured questionnaire were distributed to staff of 3 major industrial firms in Calabar (Niger Flour Mills, United Cement Company and Dangote Group). 204 (92.73%) of them filled and returned theirs, while 26 (7.27%) could not. The respondents were aged between 20 to 65 years. The data were tested with criterion mean, where Very High Extent (VHE) = 4 points; High Extent (HE) = 3 points; Moderate Extent (ME) = 2 points, Low Extent (LE) = 1 point; and No Extent (NE) = 0 point.

Objective 1: To analyse the extent of application of modern inventory technology by Nigerian manufacturing firms.

S/ N	Issues	Very High Extent	High Extent	Mod- erate	Low Extent	No extent	Mea- n	Decision
1	My company applies modern inventory technologies and computerized systems such as the Radio Frequency Identification (RFID)	10 (40)	15 (45)	33 (66)	67 (67)	79 (0)	1.06	Disagree d
2	My company applies modern inventory technologies such as barcodes, vending machines and warehouse technology management system	14 (56)	23 (69)	41 (82)	55 (55)	71 (0)	1.28	Disagree d
3	My company's inventory technology system provides us with accurate information on a constant basis to enhance organisation's productivity	45 (180)	51 (153)	45 (90)	43 (43)	20 (0)	2.28	
	Grand Mean						1.54	Disagree d

Source: Field survey, 2016.

Test of Objective One**Test Statistics: Criterion Mean****Decision Rule:**

If Mean is less than 1.99 ($\text{Mean} < 1.99$), the Respondents Disagree.

If Mean is equal to 1.99 but less than 2.0 ($\text{Mean} = 1.99 < 2.0$), the Respondents are Undecided.

If Mean is ≥ 2.0 the Respondents Agree.

Interpretation of Results

With a Mean of 1.06, majority of the respondents disagreed that their companies are applying modern inventory technologies and computerized systems such as the Radio Frequency Identification (RFID) in their operations. With a Mean of 1.28, majority of the respondents once more disagreed that their companies apply modern inventory technologies such as barcodes, vending machines and warehouse technology management system. Meanwhile, with a Mean of 2.28, majority of the respondents affirmed that their companies' inventory technology system provide them with accurate information on a constant basis to enhance organisation's productivity. However, all these gave a cumulative Mean score of 1.54, indicating acceptance of the null-hypothesis which holds that: "The application of modern inventory technology by Nigerian manufacturing firms is insignificant."

Objective 2: To ascertain the effect of level of application of modern inventory technology by Nigerian manufacturing firms on their corporate performance

S/ N	Issues	Very High Extent	High Extent	Modera te	Low Extent	No extent	Mea n	Decision
4	The level of application of modern inventory technologies by my company have significant positive effect on our production process	39 (156)	36 (108)	35 (70)	43 (43)	51 (0)	1.85	Disagree d
5	The level of application of modern inventory technologies by my company improves our warehousing function very significantly	28 (112)	33 (99)	37 (74)	46 (46)	60 (0)	1.62	Disagree d
6	The level of application of modern inventory technologies by my company has significant positive effect on our overall corporate performance	55 (220)	46 (138)	33 (66)	39 (39)	31 (0)	2.27	Agreed
	Grand Mean						1.91	Disagree d

Source: Field survey, 2016.

With a Mean of 1.85, majority of the respondents disagreed that their companies level of application of modern inventory technologies have significant positive effect on their production process. With a Mean of 1.62, majority of the respondents disagreed that the application of modern inventory technologies by their companies improved their warehousing function very significantly. Meanwhile, with a Mean of 2.27, majority of the respondents concored that the level of application of modern inventory technologies by their companies have significant positive effect on their overall corporate performance. However, all these gave a cumulative Mean score of 1.91, indicating acceptance of the null-hypothesis which states that: "Majority of Nigerian manufacturing firms do not significantly apply modern inventory technologies in their operations."

Summary of Findings and their Implications

A summary of the findings of the study are as follows:

- i. Majority of Nigerian manufacturing firms do not significantly apply modern inventory technologies in their operations.
- ii. The level of application of modern inventory technologies by Nigerian manufacturing firms has no significant positive effect on their corporate performance.
- iii. The inventory technology adoption levels of the Nigerian manufacturing firms have no significant positive effect on their employment generation and GDP contributions to the economy.

The implications of the above-stated findings are that Nigeria manufacturing firms should endeavour to replace manual data collection activities with technology-based systems whenever possible. Besides improving accuracy, electronic data collection is faster than manual collection, which is more labour intensive. Replacing paper forms with much smaller bar code labels, for example, produces media savings that frequently reach six figures annually – even for companies with moderate levels of items-tracking and shipping activity. Inventory technologies can create sustainable advantages by providing the accurate information required for modern business practices. By implementing technology-based inventory management, Nigeria manufacturing firms can realize significant return on investment (ROI) and thus, contribute significantly to the GDP growth rate in the country.

CONCLUSION

The study revealed that there is strong need for government-industry policy on inventory management technology for enhanced productivity and GDP growth rate in Nigeria. According to the findings, majority of Nigerian manufacturing enterprises are more or less completely dependent on manual inventory operations. It is worrisome to observe that inspite of these avalanche of government policies and incentives on the manufacturing sector, it is yet to contribute meaningfully to the nation's GDP or compete globally.

RECOMMENDATIONS

Based on the findings of this study, the following recommendations were proffered:

- i. There should be a government-industry policy that would mandate the use of inventory technology by manufacturers in Nigeria in managing their available assets for enhanced productivity and GDP growth rate in the country.
- ii. Also, tertiary institutions should link schools to work: sound and qualitative education for university students on the technicality and application of inventory management technology.
- iii. Finally, there should be sensitization of manufacturers on the immeasurable advantages of technology in managing inventories in order to enhance their operating capacities.

REFERENCES

- Ajayi, D. D. (2001). 'Industrial Subcontracting Linkages in the Lagos Region, Nigeria', *The Nigerian Journal of Economic and Social Studies (NJESS)*, Vol. 43 (2): 265-277.
- Christian, R. (2013). *Back to Basics: Inventory Handling and Tracking Technologies*. www.mhlnews.com.
- Ebitu, E. T. (2014) *Distribution and Logistics Management*. 2nd Edition. Calabar. University of Calabar Printing Press.
- Eleje, U. (2009). *Critical Writing*, <http://www2.southeastern.edu/Academics/Faculty/elejeune/critique.htm>

- Eteng, E. U. (2008). *Production Management: An Introductory Perspective*. 2nd Edition. Calabar. Be-Umor Nig. Ltd.
- Etuk, E. J. (2010). *Business Research Methods: Concepts, processes and applications*. Calabar. University of Calabar Press.
- Farese, F.; Kimbrell, G.; & Woloszyk C. (1997). *Marketing Essentials*. 2nd Edition. New York. Glencoe McGraw-Hill.
- Goksoy, A., Vayvay, O., Ergeneli, N., (2013). Gaining competitive advantage through innovation strategies: An application in Warehouse Management Process. *American Journal of Business and Management*, Vol. 2. No.4. 304-321
- Golding, P. and Tennant, V. (2008). Using RFID inventory reader at the item-level in a library environment: Performance Benchmark. Jamaica, University of Technology.
- Griffin, D. (2015) Perpetual Inventory System & Definition. Demand media; online
- Griffiths, A. et al, (2011). An electronic inventory system designed to aid compliance with National select agents registry program. Texas. Biomedical Institute. *Applied biosafety* Vol. 16. No.1
- Hamlett, J. (2006). Cultivating Alliances with Customers. *International Journal of Organizational Management*, New York. Vol. 7. Issue 3, pp. 255-287
- Harry, E.G. (2005). *Tracking Inventory*. London: Underwood Pitman
- Iruka, C. H. (2003). *Organizational purchasing & materials management: principles and application*. Nigeria. Springfield Publishers Ltd.
- Kenneth. D.C. (2002). *Contemporary Inventory Management Systems*. New York: McGraw Go Spot.
- Kotler, I.C. (2003). *Inventory Control Management in the 21st Century*.
- Kotler, P. (2010). *Principles of marketing (13th Ed)* Upper saddle River NJ. Pearson Education.
- Lwiki, T. et al. (2013). The impact of inventory management practices on financial performance of sugar manufacturing firms in Kenya, in *International Journal of business, humanities and technology*. Vol. 3, No. 5; P75-79
- Lysons, K. (2001). *Purchasing and supply chain management*. London: Prentice Hall
- Mathaba S. et al (2011). *Electronic Journal of Information systems evaluation*. Vol. 14; Issue 2.
- Mickle, M. H. (2007). "Establishment of the University of Pittsburgh RFID Center of Excellence," *IEEE Applications and Practice Magazine*.
- Microsoft Encarta Dictionary, (2009). *Inventory*. Retrieved May 24, 2011.
- Monga, A. and Singh, B. (2012). *International Journal of VLSI design and communication systems*. Vol. 3. No.2, 19 – 22.
- National Bureau of Statistics (NBS, 2012). *Nigerian Manufacturing Sector: Sectoral Analysis*. <http://www.nigerianstat.gov.ng/sectorstat/sectors/Manufacturing>
- Nikitin, P. V. (2008). Using National Instruments Software and Hardware to Develop and Test RFID Tags. *IEEE Applications and Practice Magazine*
- Onuoha, B. C. (2009). Policies on Improving Industrial Development and Competitiveness in Nigeria: An Appraisal. *Journal of Finance, Banking and Investment* 3(1).
- Onuoha, B.C. (2013). Factors militating against the global competitiveness of manufacturing firms in Nigeria. *American International Journal of Contemporary Research*. Vol. 3 No. 4; April 2013
- Palgrave Macmillan (2006). *Critical analysis*, <http://www.palgrave.com/studentstudyskills/.../critical%20analysis%20.pdf>

- Safizadeh, M. H. and Larry P. R. (1997). "Linking Performance Drivers in Production Planning and Inventory Control to Process Choice." *Journal of Operations Management*.
- Sande, O.F. (2003). Automated Warehouse Management Systems. *Journal of Information Technology, Massachusetts*. Vol. 2, pp. 35-43.
- Singh, Y., & Pandey, M. (2009), *International Business and Marketing Management*. India. A.I.T.B.S. Publisher.
- Udo, G. J. (1993). "The Impact of Telecommunications on Inventory Management." *Production and Inventory Management Journal*. Spring.
- UW.edu (2014). How to Write a Critical Analysis, <https://www.tacoma.uw.edu/sites/.../files/.../howtowriteacriticalanalysis.pdf>
- Webster's New World Telecom Dictionary (2010). Indianapolis, Indiana, Wiley Publishing, Inc.,.
- Zebra technologies white paper (2014). <http://zebratechnology.com/whitepaper>
- Zenz, A.Z. (2004). *How Inventory Control Systems Really Work*. New Jersey USA: Peterson Educational Inc.