

## AN HPSG APPROACH TO FREE RELATIVES IN ARABIC

**Abdulrahman Alqurashi**

King Abdulaziz University

aaalqurashi@kau.edu.sa

---

**ABSTRACT:** *This paper describes free relative constructions in Modern Standard Arabic (henceforth, MSA) and aims to provide an HPSG analysis for them. MSA has two types of free relative constructions. One, which is introduced by the complementizer ʔallaḍi, looks just like a relative clause. The other, which is introduced by the elements man and maa, which also appear to be complementizers, does not look like a relative clause. Both types can be analysed in term of unary-branching structures (as NPs consisting just of a CP). In ʔallaḍi free relatives, the NP and the value of SLASH can be coindexed via the value of MOD on the CP. In man and maa free relatives, the NP and the value of SLASH must be coindexed directly.*

**KEYWORDS:** Free Relative, Arabic, HPSG, SLASH

---

### INTRODUCTION

There has been a limited amount discussion of free relatives within the HPSG framework. Kim (2001), Lee (2001) and Wright & Kathol (2002) have proposed an HPSG analysis for free relatives in English. Müller (1999) has discussed free relatives in German and Borsley (2008) has analyzed free relatives in Welsh. The central question in these proposals is whether the initial *wh*-phrase is treated as the head, as the filler or as both. However, to the best of knowledge, Arabic free relatives have not been discussed within HPSG framework yet. As we will see, they raise somewhat different issues from free relatives in English, German and Welsh.

In this paper, I will propose a unary-branching approach for Arabic free relatives which is somewhat like Müller's (1999) approach for German free relatives. However, the analysis developed here is different from Müller's analysis since the properties of Arabic free relatives are different from those of German free relatives and many other languages. Arabic free relatives are introduced by a complementizer and not by a *wh*-phrase, as will be discussed in Section 3. Therefore, the question of whether the initial *wh*-phrase is treated as the head, as the filler or as both does not arise here. This suggests that the analysis of free relatives will be rather different from the analysis of free relatives in English and other languages that have been discussed within the HPSG framework.

---

↑ I am grateful to my supervisor, Bob Borsley, Michael Hahn, Stefan Müller and three anonymous reviewers of HPSG 2012 for their constructive and helpful comments on an early version of this paper. Any errors or inaccuracies are my responsibility alone.

**THE DATA**

Free relatives in MSA are unbounded dependency constructions which involve both gaps and resumptive clitics and involve three different free relative markers *ʔallaði*, *man* and *maa*. I use the term ‘free relative marker’ (FRM) for these elements pending discussion of their syntactic status.

- (1) *jaaʔa* [ *ʔllaði* *faaza* \_\_\_\_ *fi* *l-musabaqat-i*].  
 came. 3.M.SG FRM.M.SG won.3.M.SG in DEF-competition-GEN  
 ‘The one that won the competition came.’
- (2) *raʔaytu* [ *man* *yuhib-haa* *Ali*].  
 saw.1.SG FRM like.3.M.SG-3.F.SG Ali  
 ‘I saw the one (female) that Ali likes.’
- (3) *hadaθaa* [ *maa* *ʔaxšaa-hu*].  
 happened.3.M.SG FRM fear.1.SG-3.M.SG  
 ‘The thing that I fear happened.’

There is a semantic difference between the three markers *ʔallaði*, *man* and *maa*. *man* and *maa* have certain restrictions on their reference. The former is used in free relative clauses that refer to animate entities whereas the latter is used in free relative clauses that refer to inanimate entities. The following ungrammatical examples with *man* and *maa* illustrate these restrictions.

- (4) \**jaaʔa* [ *maa* *faaza* \_\_\_\_ *fi* *l-musabaqat-i*].  
 came. 3.M.SG FRM won.3.M.SG in DEF-competition-GEN  
 Intended: ‘The thing that won the competition came.’
- (5) \**hadaθaa* [ *man* *ʔaxšaa-hu*].  
 happened.3.M.SG FRM fear.1.SG-3.M.SG  
 Intended: ‘The one that I fear happened.’

*ʔallaði*, on the other hand, can be associated with both animate and inanimate entities and hence it can replace *man* and *maa*.

The markers *man* and *maa* are invariant but *ʔallaði* is inflected for number, gender and sometimes for case as the following table illustrates.

	<b>Masculine</b>	<b>Feminine</b>
<b>Singular</b>	<i>ʔallaði</i>	<i>ʔallati</i>
<b>Dual-NOM</b>	<i>ʔallaðaani</i>	<i>ʔallataani</i>
<b>Dual-ACC/GEN</b>	<i>ʔallaḏayni</i>	<i>ʔallatayni</i>
<b>Plural</b>	<i>ʔallaðiina</i>	<i>ʔallaati-allawaati</i>

This might suggest that *ʔallaði* is a kind of *wh*-pronoun. However, I will argue in Section 3 that the free relative markers *ʔallaði*, *man* and *maa* are complementizers and not *wh*-pronouns.

As one might expect, free relatives in SA can appear in the full set of NP positions. The following examples show that they can appear in subject position as in (6a) and (6b), in object position as in (6c), in the prepositional object position as in (6d) and in possessor position as in (6e). The following examples are given with the free relative marker *ʔallaði*. Free relatives with the markers *man* and *maa* have the same distribution.

- (6) a. *ħadaθaa* [*llaði* *ʔaxšaa-ħu*].  
 happened.3.M.SG FRM.M.SG fear.1.SG-3.M.SG  
 ‘The thing that I fear happened.’
- b. [*llaði* *ʔaxšaa-ħu*.] *ħadaθaa*.  
 FRM.M.SG fear.1.SG-3.M.SG happened.3.M.SG  
 ‘The thing that I fear happened.’
- c. *raʔaytu* [*llatayni* *yuhib-ħumaa* *Ali*].  
 saw.1.SG FRM.F.DUAL.ACC like.3.M.SG-3.F.DUAL *Ali*  
 ‘I saw the two (female) that *Ali* likes.’
- d. *taħdaθtu* *mafa* [*llaði* *taħdaθta* *mfa-ħu*].  
 spoke.1.SG with FRM.M.SG spoke.2.M.SG with-3.M.SG  
 ‘I spoke with the one that you spoke with.’
- e. *ʔimtalaktu* *qalba* [*llati* *ʔuhib-ħaa*].  
 possessed.1.SG heart FRM.F.SG love.1.SG-3.F.SG  
 ‘I possessed the heart of the one that I love.’

When the free relative is in the subject position as in (6a) and (6b), the verb of the main clause agrees with *ʔallaði* in person, number and gender. In addition, when case is visible, it reflects the position of the free relative as in (6c).

The relative marker *ʔallaði* and its various forms also appear in ordinary relative clauses modifying an NP. In fact, there are two types of restrictive relative clauses: restrictive relatives with a definite relativized antecedent (definite relatives) as in (7a) and restrictive relatives with an indefinite relativized antecedent (indefinite relatives) as in (7b). (see. Aoun et al., 2010; Alqurashi and Borsley, 2012). The relative marker *ʔallaði* appears only in definite relatives but the markers *man* and *maa* do not as illustrated by the following examples.<sup>2</sup>

- (7) a. *raʔaytu* *l-fatat-a* [*llati* *ʔuhib-ħa*].<sup>3</sup>  
 saw.1.SG DEF-girl-ACC RM.F.SG like.1.SG-3.F.SG  
 ‘I saw the girl that I like.’

<sup>2</sup> The indefinite relatives are bare clauses modifying an indefinite antecedent in which *ʔallaði* does not appear. (see Alqurashi and Borsley, 2012).

<sup>3</sup> I gloss *ʔallati* as ‘relative marker’ (RM) and not as FRM because it is used here to introduce a restrictive relative clause, not a free relative clause.

b. raʔaytu fatatt-an [ʔuhib-**ha**].  
 saw.1.SG girl-ACC like.1.SG-3.F.SG  
 ‘I saw a girl that I like.’

(8) \*raʔaytu l-fatat-a [*man* ʔuhib-**ha**].  
 saw.1.SG DEF-girl-ACC FRM.F.SG like.1.SG-3.F.SG  
 Intended: ‘I saw the girl that I like.’

(9) \*šahadtu l-šayʔ-a [*maa* ḥadaṯa].  
 witnessed.1.SG DEF-thing-ACC FRM happened.3.M.SG  
 Intended: ‘I witnessed the thing that happened.’

The feminine form *ʔallati* in (7a) agrees with the antecedent *l-fatat-a* and with the clitic *ha* in number and gender. In free relatives, the relative markers *ʔallaḍi* and its various forms, *man* and *maa* agree in number and gender with the clitic or the gap inside the relative clause. This can be identified either by the verb inside the relative clause in case where a gap is involved or by the clitic where resumption is involved.

(10) a. qaabaltu [ʔallaḍiina faazuu fi l-musabaqat-i].  
 met.1.SG FRM.M.PL won.3M.PL in DEF-competition-GEN  
 ‘I met the ones that won the competition.’

b. raʔaytu [ʔallaḍiina yuhib-**hum** Ali].  
 met.1.SG FRM.M.PL like.3.M.SG-3.M.PL Ali  
 ‘I saw the ones that Ali likes.’

c. raʔaytu [*man* yuhib-**hum** Ali].  
 met.1.SG FRM like.3.M.SG-3M.PL Ali  
 ‘I saw the ones that Ali likes.’

d. ʔaʕrifu [*maa* taxšaa-**huma** Hind].  
 know.1.SG FRM fear.3.F.SG-RP.DUAL Hind  
 ‘I know the two things that Hind fears.’

A further point that we should consider here is whether Arabic free relatives can be extraposed like in German, for example. Let us first consider the German data and then compare them with the Arabic ones.

Müller (1999) points out that free relative clauses in German, as in (11d), can be extraposed like ordinary relative clauses, as in (11a). According to Müller (1999:70), “relative clauses in German are finite clauses with the finite verb in final position if nothing is extraposed and if the verbs are in normal order” as illustrated by the example in (11a). The following examples are taken from Groos and van Riemsdijk (1981:185).

(11) a. Der Hans hat [das Geld, das er gestohlen hat], zurückgegeben.  
 the Hans has the money that he stolen has returned  
 ‘Hans has returned the money that he has stolen.’

b. Der Hans hat [das Geld  $t_i$ ] zurückgegeben, [das er gestohlen hat] $_i$ .

- the Hans has the money returned that he stolen has  
 c. \*Der Hans hat  $t_i$  zurückgegeben, [das Geld, das er gestohlen hat]<sub>i</sub>.  
 the Hans has returned the money that he stolen has  
 d. Der Hans hat  $t_i$  zurückgegeben, [was er gestohlen hat]<sub>i</sub>.  
 the Hans has returned what he stolen has  
 ‘Hans has returned what he has stolen.’

A first glance at the Arabic free relative example in (12) below might suggest that they too can be extraposed. The free relative clause in the following example appears in final position although it is understood as the subject.

- (12) jaaʔa ʔila l-lbayt-i [llaḏi ušbihhu  
 came.3.M.SG to DEF-house-GEN FRM.M.SG looks like.3.M.SG  
 ʔaba-**hu**].  
 father-3.M.SG  
 ‘The one that looks like his father came to the house.’

However, Arabic relative clauses cannot be extraposed as the following example illustrates:

- (13) \*jaaʔa [l-walad-u] ʔila l-lbayt-i [llaḏi  
 came.3.M.SG DEF-boy-NOM to DEF-house-GEN RM.M.SG  
 ušbihhu ʔaba-**hu**].  
 looks like.3.M.SG father-3.M.SG  
 ‘The boy that looks like his father came to the house.’

In fact, it seems that what we have in (12) is not an extraposition, but rather an example of a complex subject occupying a noncanonical position. This is supported by the fact that complex NPs containing a relative clause can appear in the same position.

- (14) jaaʔa ʔila l-lbayti [l-walad-u llaḏi  
 came.3.M.SG to DEF-house-GEN DEF-boy-NOM RM.M.SG  
 ušbihhu ʔaba-**hu**].  
 looks like.3.M.SG father-3.M.SG  
 ‘The boy that looks like his father came to the house.’

Moreover, Arabic free relatives have the same distribution as equally complex NPs. They have certain marked word order as illustrated by the following examples:

- (15) **Complex NPs in subject position:**  
 a. ʔazʕaja [kalam-u Ahmad-in] Hind-an.  
 annoyed.3.M.SG speech-NOM Ahmad-GEN Hind-ACC  
 b. ʔazʕaja Hind-an [kalam-u Ahmad-in].  
 annoyed.3.M.SG Hind-ACC speech-NOM Ahmad-GEN  
 ‘Ahmad’s speech annoyed Hind’

- (16) **Free relative in Subject position:**  
 a. ʔazʕaja [maa qala-**hu** Ahmad-un] Hind-an.  
 annoyed.3.M.SG FRM said.3.M.SG-3.M.SG Ahmad-nom Hind-ACC

- b. ʔazʕaja Hind-an [maa qala-**hu** Ahmad-un].  
 annoyed.3.M.SG Hind-ACC FRM said.3.M.SG-3.M.SG Ahamd-NOM  
 ‘What Ahmad said annoyed Hind.’

**(17) Complex NPs in object position:**

- a. ʔaaḏaa Ali-un [mašaʕir-a Hind-in] l-baarihata.  
 hurt.PAST.3.M.SG Ali-NOM feelings-ACC Hind-GEN DEF-yesterday  
 b. ʔaaḏaa Ali-un l-baarihata [mašaʕir-a Hind-in].  
 hurt.PAST.3.M.SG Ali-NOM DEF-yesterday feelings-ACC Hind-GEN  
 ‘Ali hurt Hind’s feelings yesterday.’

**(18) Free relatives in object position:**

- a. ʔaaḏaa Ali-un [man yuhibu-**ha**] l-baarihata.  
 hurt.PAST.3.M.SG Ali-NOM FRM like.1SG-3.F.SG DEF-yesterday  
 b. ʔaaḏaa Ali-un l-baarihata [man yuhibu-**ha**].  
 hurt.PAST.3.M.SG Ali-NOM DEF-yesterday FRM like.1SG-3.F.SG  
 ‘Ali hurt the one whom he loves.’

If restrictive relatives cannot be extraposed as shown in (13) above, it seems reasonable to assume that (12) above is an example of a complex NP in a noncanonical position, not of extraposition.

**THE SYNTACTIC STATUS OF ʔallaḏi, man and maa**

I argue that the free relative markers: *ʔallaḏi*, *man* and *maa* are complementizers and not *wh*-pronouns.<sup>4</sup> This position is supported by the fact that these markers cannot be a part of a larger clause-initial constituent as one would expect if they were pronouns. *Wh*-interrogative pronouns, for example, can be part of a larger clause initial phrase as the following examples illustrate.

- (19) a. [PP maʕa man] takallamta ?  
 with whom talked.2.MSG  
 ‘With whom did you talk?’  
 b. [NP ʔom man] maatat?  
 mother whose died.3.FSG  
 ‘Whose mother died?’

In contrast, the free relative markers *ʔallaḏi*, *man* and *maa* behave differently from *Wh*-interrogative pronouns with respect to pied piping. The following ungrammatical examples in (20) show that *ʔallaḏi*, *man* and *maa* cannot be a part of a clause-initial PP. The grammatical counterparts shown in (21) have in-situ preposition with a resumptive clitic.

<sup>4</sup> Aoun, Benmamoun and Choueiri (2010) also assume that *ʔallaḏi* is a complementizer, but they provide no arguments for this position.

- (20) a. \*qaabaltu [PP maŋ *llaði*] takallamta.  
met.1.SG with RM.M.SG talked.2.M.SG  
Intended: 'I met with whom you talked.'
- b. \*qaabaltu [PP maŋ *man*] takallamta.  
met.1.SG with FRM talked.2.M.SG
- c. \*aŋjabani [PP ŋan *maa*] taḥdaθta.  
liked.1.SG about FRM spoke.2.M.SG  
Intended: 'I liked about what you spoke.'
- (21) a. qaabaltu [*llaði* taḥdaθta maŋ-**hu**].  
met.1.SG RM.M.SG spoke.2.M.SG with-3.M.SG  
'I met the one whom you spoke with.'
- b. qaabaltu [*man* taḥdaθta maŋ-**hu**].  
met.1.SG FRM spoke.2.M.SG with-3.M.SG  
'I met the one whom you spoke with.'
- c. aŋjabani [*maa* taḥdaθta ŋan-**hu**].  
liked.1.SG FRM spoke.2.M.SG about-3.SG  
'I liked the thing that you spoke about.'

However, the above examples in (20) do not prove much because there is an alternative interpretation for the ungrammaticality of these examples. This is that the free relative markers in (20) are *wh*-pronouns and thus the sentence is ungrammatical due to the matching effects which require the initial phrase to be whatever category is required in the position where the free relative appears (see Bresnan and Grimshaw (1978) and Gross and van Riemsdijk (1981) for discussion of the matching effects in free relatives). However, there is another way to reveal the syntactic status of these markers which is to examine whether they can be a possessor within a clause-initial NP. The following ungrammatical examples in (22) show that this is not possible. Their grammatical counterparts are shown in (23).

- (22) a. \*ʔaŋrifu [NP ʔbu *llati* maat].  
know.1.SG father FRM.F.SG died.3.M.SG  
Intended: 'I know the one whose father died.'
- b. \*ʔaŋrifu [NP ʔbu *man* maat].  
know.1.SG father FRM. died.3.M.SG  
Intended: 'I know the one whose father died.'
- c. \*ḥadaθaa [NP ŋawaqiba *maa* ʔaxšaa].  
happened.3.M.SG consequences FRM fear.1.SG  
Intended: 'The thing whose consequences I fear happened.'
- (23) a. ʔaŋrifu [*llati* maat ʔbu-**ha**].  
know.1.SG FRM.F.SG died.3.M.SG father-3.F.SG  
'I know the one whose father died.'



- b.  $\text{ʔaʕrifu}$  [*man* *maat* *ʔbu-ha*].  
 know.1.SG FRM.F.SG died.3.M.SG father- 3.F.SG  
 ‘I know the one whose father died.’
- c. *hadaθaa* [*maa ʔaxšaa ʕawaqiba-hu*].  
 happened.3.M.SG FRM fear.1.SG consequences-3.M.SG  
 ‘The thing whose consequences I fear happened.’

These examples cannot be ruled out by matching effects. Hence they show clearly that the free relative markers cannot be part of a larger clause initial phrase.

Further evidence supporting the argument that *ʔallaði* is a complementizer comes from relative clauses. As noted above, *ʔallaði* can also appear in ordinary relative clauses modifying an NP in which *ʔallaði* agrees with the antecedent and with the gap in number and gender. However, when case is involved, *ʔallaði* bears the case of the antecedent and not that of the gap or the RP in the relativized position.

- (24) a. *raʔaytu* *l-waladayni* [*llaðayni*  
 saw.1.SG DEF-boy-DUAL.ACC RM.M.DUAL.ACC  
*qaabala-humaa* *l-malik-u*].  
 met.3.M.SG-.DUAL DEF-king-NOM  
 ‘I saw the two boys whom the king met.’
- b. *jaaʔa* *l-waladaani* [*llaðaani*  
 came.3.M.SG DEF-boy-DUAL.NOM RM.M.DUAL.NOM  
*qaabala-humaa* *l-malik-u*].  
 met.3.M.SG-DUAL DEF-king-NOM  
 ‘The two boys whom the king met came.’

In free relatives, *ʔallaði* has a case determined by its position which is different from that of the position relativized as illustrated by the following examples.

- (25) a. *raʔaytu* [*llaðayni* *qaabala-humaa* *l-malik-u*].  
 saw.1.SG FRM.M.DUAL.ACC met.3.M.SG-.DUAL DEF-king-NOM  
 ‘I saw (the two) whom the king met.’
- b. *jaaʔa* [*llaðaani* *qaabala-humaa* *l-malik-u*].  
 came.3.M.SG FRM.M.DUAL.NOM met.3.M.SG-DUAL DEF-king-NOM  
 ‘(The two) whom the king met came.’

In addition, *ʔallaði* in ordinary relatives cannot be part of a clause-initial PP as shown by the ungrammatical example in (26a).

- (26) a. \**r-rajul-u* [[*pp maʕ llaði*] *takallamta*].  
 DEF-man-NOM with RM.M.SG talked.2.M.SG  
 Intended: ‘The man with that you talked.’
- b. *r-rajul-u* [*llaði* *takallamta* *maʕ-hu*].  
 DEF-man- NOM RM.M.SG talked.2.M.SG with-3.M.SG  
 ‘The man that you talked with.’



At this stage, we can conclude on the basis of the above discussion that *ʔallaḏi* is a complementizer. It is natural to conclude that *man* and *maa* are complementizers too. However, it is worth considering the possibility that they are nouns.

I argue that *man* and *maa* cannot be treated as nouns for the following reasons. First, they are invariant in form and in particular that they are not inflected for Case as discussed above. Second, nouns in Arabic can be modified by adjectives. Therefore, if *man* and *maa* were nouns, we would expect them to be modified by adjectives, but the following examples show that they cannot.

- (27) a. \*raʔaytu [man l-jamiilat-a yuhib-haa Ali].  
 saw.1.SG FRM.F.SG DEF-beautiful.ACC like.3.M.SG-3.F.SG Ali  
 Intended: 'I saw the beautiful one (female) that Ali likes.'
- b. \*hadaḥaa [maa l-muzʕij-u ʔaxšaa-hu].  
 happened.3.M.SG FRM DEF-annoying.NOM fear.1.SG-3.M.SG  
 Intended: 'The annoying thing that I fear happened'

Finally, nouns don't take a bare clause as a complement, but only a clause introduced by a complementizer as in (28), whereas *man* and *maa* take a bare clause as a complement.

- (28) a. ʔal-ḥaqiqat-u ʔanna Ahmad-an yuhibu Hind-an.  
 the-fact that Ahmad-ACC love.3.M.SG Hind-ACC  
 'The fact is that Ahmad loves Hind.'
- b. wajadtu l-kitab-a [llaḏi tuhib-hu Salwa].  
 found.1.SG DEF-book-ACC RM. M.SG like.1.SG-3.SG Salwa  
 'I found the book that Salwa likes.'

The question that might arise here is whether *man* and *maa* are indefinite nouns like the antecedent in indefinite relatives which takes a bare clause as its complement. We can exclude this by arguing that the clause following *man* and *maa* cannot be a relative clause given that the latter is optional after the noun it modifies whereas the former is obligatory after *man* and *maa* as demonstrated by (29) and (30) below.

- (29) \*raʔaytu [man .....]  
 saw.1.SG FRM  
 Intended: 'I saw the one that ...'
- (30) \*hadaḥaa [maa .....]  
 happened.3.M.SG FRM  
 Intended: 'what... happened'

Therefore, I conclude that *ʔallaḏi*, *man* and *maa* are complementizers. *man* and *maa* appear only in free relatives whereas *ʔallaḏi* appears in both ordinary relative clauses and free relatives. However, these complementizers are different from the sentential complementizers *ʔan* and *ʔanna* which introduce complement clauses as the following illustrates:

- (31) a.  $\text{ʔiqtarhtu}$   $\text{ʔan yuʃarika}$   $\text{Ahmad-un}$   $\text{fi l-musabaqah}$ .  
 suggested.1.SG that participate Ahmad-NOM in DEF-competition  
 ‘I suggested that Ahmad participate in the competition.’
- b.  $\text{qultu}$   $\text{li-Ahmad}$   $\text{ʔanna Hind-an}$   $\text{tuhibu-hu}$ .  
 said.1.SG to-Ahmad that Hind-ACC love. 3.F.SG-him  
 ‘I said to Ahmad that Hind loves him.’

## THE NATURE OF GAPS AND RESUMPTIVE CLITICS

As noted above, both gaps and resumptive clitics are used in Arabic free relatives. In this section, I will discuss the nature of gaps and resumptive clitics in Arabic free relatives. There are two approaches to resumptive clitics in the HPSG literature. The first is to assume that gaps and resumptive clitics are realizations of two separate NONLOCAL features: SLASH and RESUMP (Vaillette 2000) and the second is to assume that both gaps and resumptive clitics are realizations of SLASH (Borsley, 2010 and Taghvaipour, 2004 and 2005). Here, there is evidence that both gaps and resumptive clitics in Arabic are analyzed as the realization of the SLASH feature. In accordance with the Coordinate Structure Constraint of Ross (1967:161), an unbounded dependency can not affect one conjunct of a coordinate structure unless it affects the other(s) as the following example illustrates.<sup>5</sup>

- (32)  $*\text{jaaʔat}$  [ $\text{llati}$   $\text{ʔuhibu-}$   $\text{wa ʔaʃʃaq}$   $\text{Salwa}$ ].  
 came.3.F.SG that-F.SG love.1.M.SG and adore.1.M.SG Salwa  
 Intended: ‘\*The one (female) that I love and adore Salwa came.’
- (33)  $\text{jaaʔat}$  [ $\text{llati}$   $\text{ʔuhibu-}$   $\text{wa ʔaʃʃaq-}$ ].  
 came.3.F.SG that-F.SG love.1.M.SG and adore.1.M.SG  
 ‘The one (female) that I love and adore came.’

However, there are certain coordinated structures in which there is a gap in the first conjunct and a resumptive clitic in the second or vice versa as illustrated in (34) and (35).

- (34) a.  $\text{jaaʔat}$  [ $\text{llati}$   $\text{ʔuhibu-}$   $\text{wa ʔaʃʃaqu-ha}$ ].  
 came.3.F.SG that-F.SG love.1.M.SG and adore.1.M.SG -3.F.SG  
 ‘The one (female) that I love and adore came.’
- b.  $\text{jaaʔat}$  [ $\text{llati}$   $\text{ʔuhibu-}$   $\text{wa ʔaħras}$   $\text{ʃalay-ha}$ ].  
 came.3.F.SG that-F.SG love.1.M.SG and care.1.M.SG about-3.F.SG  
 ‘The one (female) that I love and care about.’
- (35) a.  $\text{jaaʔat}$  [ $\text{llati}$   $\text{ʔuhibu-ha}$   $\text{wa ʔaʃʃaqu-}$ ].  
 came.3.F.SG that-F.SG love.1.M.SG-3.F.SG and adore.1.M.SG  
 ‘The one (female) that I love and adore came.’

<sup>5</sup> Coordinate Structure Constraint: In a coordination structure, no conjunct may be moved, nor may any element contained in a conjunct be moved out of the conjunct (Ross,1967:161)

- b. jaaʔat [llati ʔaħras ʕalay-**ha** wa ʔuħibu\_\_].  
 came.3.F.SG that-F.SG care.1.M.SG about-3.F.SG and love.1.M.SG  
 ‘The girl that I love and care about’

This suggests that gap and resumptive clitics behave in the same way with respect to the Coordinate Structure Constraint and hence both gaps and RPs in Arabic should be realizations of SLASH. This entails that we utilize the SLASH feature to handle both gaps and resumptive clitics and not two separate features: SLASH and RESUMP as in Vaillette (2000).

## ANALYSIS

Since there are no previous HPSG analyses of Arabic free relatives, it is reasonable to consider how free relatives are analyzed within transformational grammar. Within a framework like Minimalism, Arabic free relatives would probably be treated like restrictive relative clauses, in which the antecedent is assumed to be base-generated and there is a movement of a null operator, except for the fact that free relatives modify a null antecedent (Alqurashi, 2013).<sup>6</sup> Someone might propose similar analysis within HPSG in which free relatives are treated like restrictive relative clauses but with a phonologically empty nominal. In fact, there are various objections to such an approach. First, it is not clear how one could insure that this empty nominal constituent does not appear without a relative clause. In other words, if we allow an empty element modified by a relative clause in various positions (e.g. subject, object, etc.), it would be very difficult to prevent this empty element appearing without a relative clause in those positions. We cannot assume, on the other hand, that this empty nominal selects for a clause because it is usually the relative clause that selects the nominal constituent they modify. Second, this analysis is excluded on the assumption that it would be possible only in the case of *ʔallaði*, which would appear in ordinary relative clauses modifying a nominal constituent, but not in the case of *man* and *maa* free relatives, which cannot introduce clauses which modify nominal heads. Our goal here is to treat the three types of free relatives as similarly as possible.

The obvious analysis within HPSG would be to assume that free relatives in Arabic are NPs which have only one daughter which is a clause.

---

<sup>6</sup> There are few works that discuss Arabic restrictive relative clauses but not free relatives within transformational grammar such as Ouhalla (2004) and Aoun, Benmamoun and Choueri (2010). Aoun et al. (2010) dedicate a whole Chapter for Arabic restrictive relatives but they do not tackle the structure. They point out that ‘this issue is a problematic one and is still under debate in the literature dealing with the topic of relativization’ (p.189). Ouhalla (2004) develops an analysis of Arabic relative clauses that does not make use of promotion but shares with Kayne’s (1994) analysis an antisymmetric view of phrase structure. The main features of Ouhalla’s analysis are (a) the idea that relatives are DPs and (b) the idea that they originate in a prenominal position. Arabic free relatives, on the other hand, have been discussed by Fassi Fehri (1978) within transformational grammar, but he uses an old version of transformational analysis which is not assumed any more.

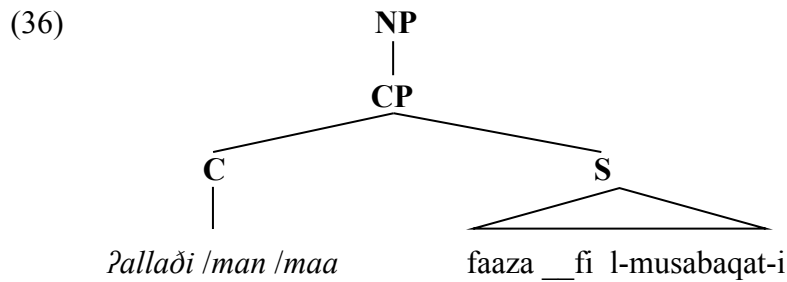

As mentioned above, this is somewhat like Müller’s (1999) unary projection approach for German free relatives. However, the analysis developed here is different from Müller’s analysis because the Arabic data shown above is quite different from German. Arabic free relatives are introduced by a complementizer and not by a *wh*-phrase and hence we should not concern with the question of whether the initial *wh*-phrase is treated as the head, as the filler or as both. Moreover, as noted above, Arabic free relatives cannot be extraposed unlike German free relatives.

The differences between the complementizer *ʔallaði* and the complementizers *man* and *maa*, outlined above, suggest that they should be treated rather differently. Thus, we need an appropriate lexical description for each complementizer. In addition, we need some constraints to capture the distinctive properties of these two types of free relatives. Let us consider *ʔallaði* free relatives first. We can assume the complementizer *ʔallaði* has the lexical description in (37). The various different forms will have different values for the NUMBER and GENDER features and the CASE of the modified NP.

(37) The lexical description for the complementizer *ʔallaði* :

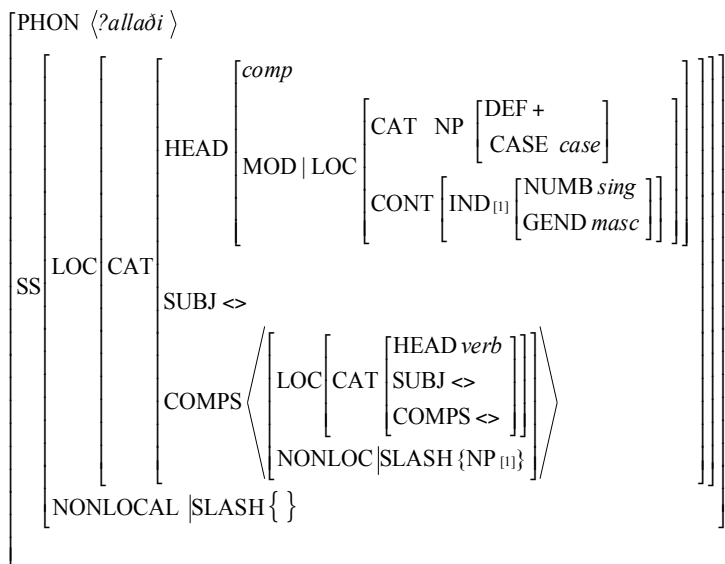

This indicates that *ʔallaði* takes a clausal complement which contains a gap or a resumptive pronoun and that the CP it heads modifies an NP coindexed with the SLASH value via the

value of MOD. This entails that the *ʔallaði* clause can modify an NP as is the case in ordinary relative clauses but it does not entail that it must do. The SLASH Amalgamation Constraint (Ginzburg and Sag, 2000), in (38), which is a default constraint, requires a head to have by default a non empty SLASH value if its complement has a non empty SLASH value.

(38) SLASH-Amalgamation constraint (Ginzburg and Sag, 2000:169):

$$word \Rightarrow / \left[ \begin{array}{l} SS | SLASH [1] \cup \dots \cup [n] \\ ARG-ST \langle [SLASH[1]], \dots, [SLASH[n]] \rangle \end{array} \right]$$

This means that the head *ʔallaði* should by default have [SLASH {NP}] because its complement (i.e. the relative clause) has [SLASH {NP}] unless there is a stipulation requiring something else. However, the lexical entry in (37) above has a stipulation which ensures that *ʔallaði* has an empty SLASH value. This will prevent the SLASH value of the internal clause from passing any further up the tree. This makes the treatment of *ʔallaði* similar to that of the English adjective *easy*. This adjective, which selects an infinitival complement missing an NP (i.e. it is [SLASH {NP}]) as in (39) below, must have an empty SLASH value which is insured by a stipulation in its lexical description.<sup>7</sup>

(39) Kim is easy to impress \_\_\_\_.

Now, we can assume that *ʔallaði* free relatives are NPs whose only daughter is a relative clause. This suggests that we need a special phrasal type for *ʔilli* / *ʔallaði* free relatives which is subject to the following constraint:

(40) *ʔallaði* -free-rel  $\rightarrow$

$$\left[ \begin{array}{l} SS | CAT NP[CASE[1], INDEX[2]] \\ DTRS \langle CP[MOD NP[CASE[1], INDEX[2]]] \rangle \end{array} \right]$$

This indicates that the *ʔallaði* free relative clause is coindexed with the value of MOD and hence has the same number and gender and also has the same CASE as shown in (6) above. The MOD value NP distinguishes *ʔallaði* clauses, which can appear as relative clauses modifying certain NPs and not just as free relatives, from *man* and *maa* clauses which appear only as free relatives as noted above. *ʔallaði* free relatives like the one in (1) above will have the structure in (41) below (I assume with Levine and Hukari (2006) that gaps are empty categories).

<sup>7</sup> See Bouma, Malouf and Sag (2001) for different approach.

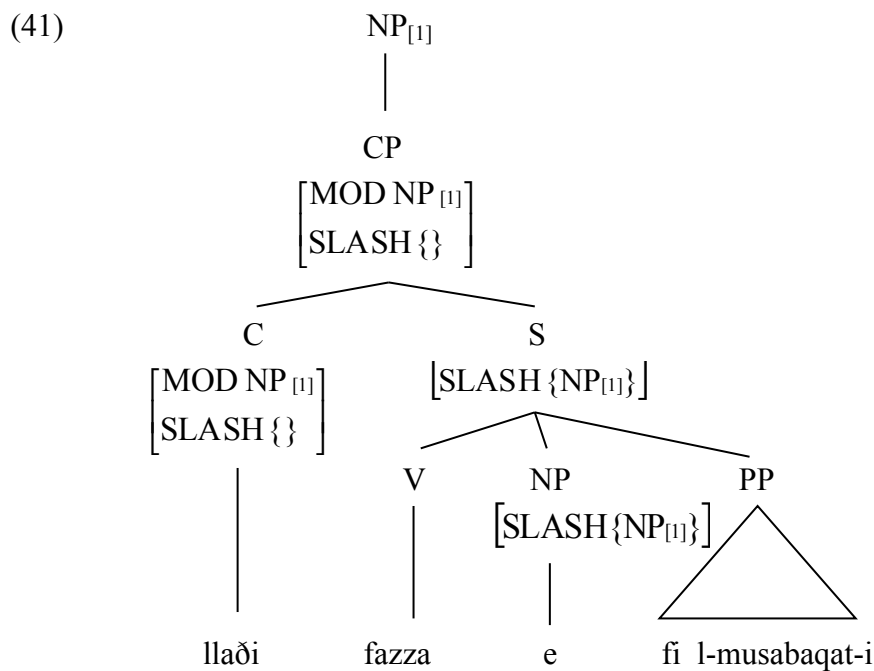

In contrast, *man* and *maa* must be specified [MOD none] like other complementizers heading clauses which are not modifiers. In the case of *llaði* free relative clauses, the dominating NP is coindexed with the value of SLASH via the value of MOD. Here, the coindexing must be ensured in some other way. It can be achieved by assuming that CPs headed by *man* and *maa* have the same value for SLASH as their complement. In other words, the complementizers *man* and *maa* should not be specified as [SLASH {}]. Free relatives with *man* and *maa* can be analysed as NPs whose only daughter is a clause but not a relative clause and they are subject to the following constraint:

$$(42) \textit{man - maa - free - rel} \rightarrow \left[ \text{SS | CAT NP [INDEX [1], SLASH {}]} \right. \\ \left. \text{DTRS} \left\langle \text{CP} \left[ \begin{array}{l} \text{MOD none} \\ \text{SLASH \{NP [INDEX [1]]\}} \end{array} \right] \right\rangle \right]$$

What is important about this constraint is that it ensures that the free relative is [SLASH {}]. This is not necessary in (40) above because the description for *llaði* in (37) above ensures that the CP is [SLASH {}].

The complementizers *man* and *maa* can be assigned the lexical descriptions in (43) and (44) below. Apart from the value of PHON which distinguishes the phonology of the complementizer *man* from that of the complementizer *maa*, there is also a pragmatic difference between them. The complementizer *man* introduces a free relative referring to an animate entity whereas the complementizer *maa* introduces a free relative referring to an inanimate entity as indicated by the values of BACKGROUND. It is worth mentioning here that these descriptions do not require *man* and *maa* to be [SLASH {}].

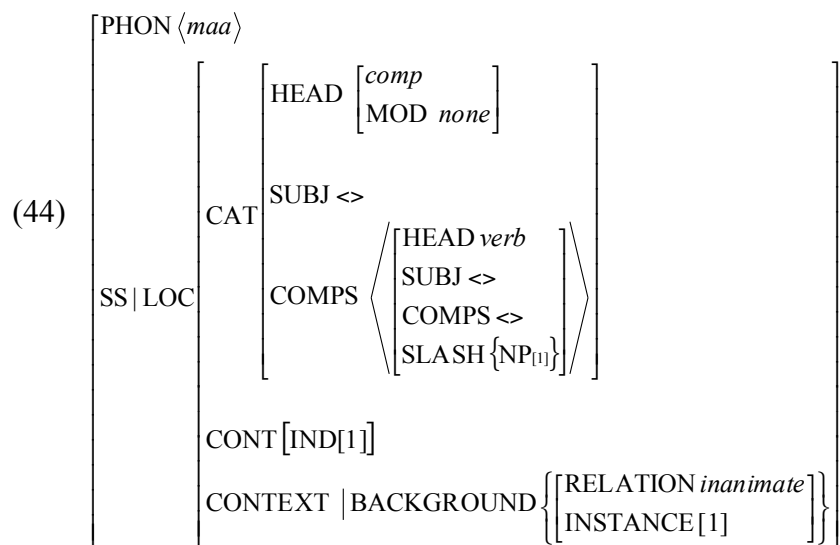
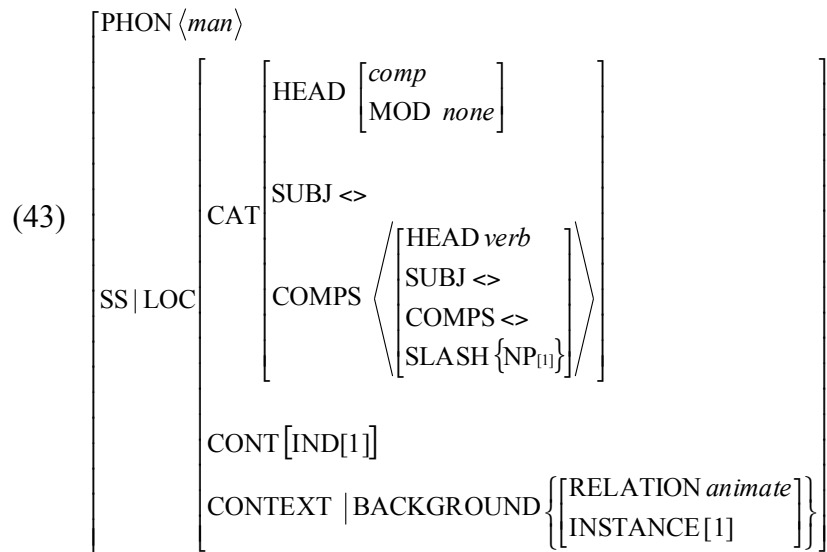

With these descriptions, *man* and *maa* free relatives like the ones in (2) and (3) above will have the structures given in (45) and (46) below.<sup>8</sup>

<sup>8</sup> I assume that null subjects in Arabic are phonologically empty elements in the constituent structure (and not just members of ARG-ST lists with no counterpart in the constituent structure). I also assume that clitics are realized as suffixes which license an empty argument. This means that both Null subjects and null elements associated with clitics appear in ARG-ST lists, in VALENCE lists and constituent structures



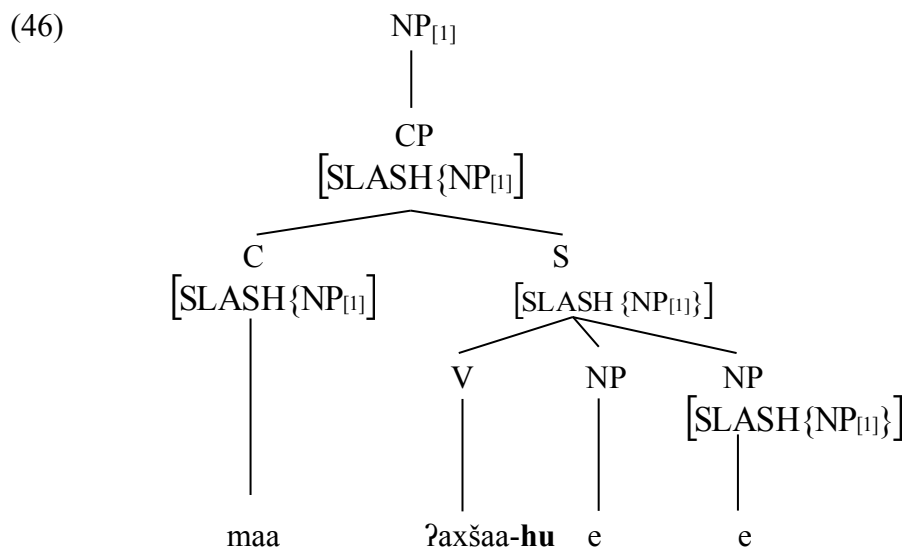
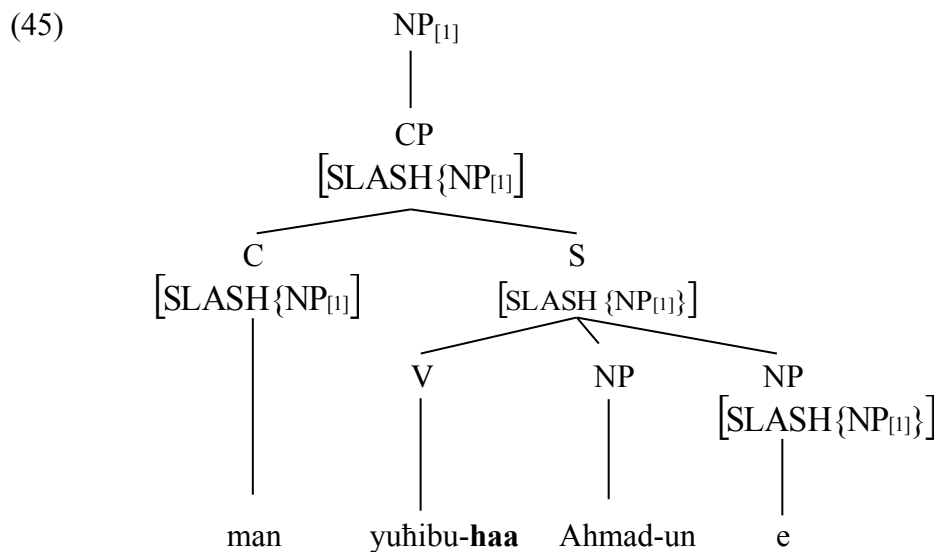

## CONCLUSION

This paper has investigated free relative constructions in Modern Standard Arabic and shown that they can be analyzed in terms of unary-branching structures (i.e. NPs consisting just of a CP) which avoids empty elements. In addition, it was shown that free relative constructions in MSA involve two types: *ʔallaḍi* -free relatives and *man-maa* free relatives. *ʔallaḍi* -free relatives look just like relative clauses in which the NP and the value of SLASH can be coindexed via the value of MOD on the CP. The other type, introduced by the complementizers *man* and *maa* does not look like a relative clause and the NP and the value

of SLASH must be coindexed directly.

In this paper, I have been concerned with two types of free relatives in MSA which seems somewhat different from those in English and other languages that have been discussed within the HPSG framework. This is due to the fact that Arabic free relatives are introduced by a complementizer and not by a *wh*-phrase. However, the analysis developed here shows that they are no problem for HPSG.

## REFERENCES

- Alqurashi, A. (2013). *Arabic free and restrictive relatives: a minimalist and an HPSG approach*. Unpublished doctoral dissertation, University of Essex.
- Alqurashi, A. and Borsley, R. (2012). Arabic relative clauses in HPSG. In S. Müller (ed.), *Proceedings of the 19<sup>th</sup> International Conference on Head-Driven Phrase Structure Grammar*, Chungnam National University Daejeon. Stanford, CA: CSLI Publications.
- Aoun, J., Choueiri, L., & Benmamoun, E. (2010). *The syntax of Arabic*: Cambridge University Press.
- Borsley, R. (2010). An HPSG approach to Welsh unbounded dependencies. In S. Müller (ed.), *Proceedings of the 17<sup>th</sup> International Conference on Head-Driven Phrase Structure Grammar*, Stanford, CA: CSLI Publications, 47–67.
- Borsley, R. D. (2008). On some Welsh unbounded dependency constructions. *Essex Research Reports in Linguistics*, 57, 1–21.
- Bouma, G., Malouf, R., & Sag, I. A. (2001). Satisfying Constraints on Extraction and Adjunction. *Natural Language & Linguistic Theory*, 19(1), 1–65.
- Fassi-Fehri, A. (1978). Comparatives and free relatives in Arabic. *Recherches Linguistiques de Vincennes*, 7, 47–88.
- Kayne, R. (1994). *The antisymmetry of syntax*: The MIT Press.
- Kim, J. B. (2001). Constructional constraints in English free relative constructions. *Korean Society for Language and Information*, 5, 35–53.
- Lee, H. (2001). English free relative constructions: A constraint-based approach. Unpublished manuscript. Seoul National University.
- Levine, R. D. and T. E. Hukari (2006), *The Unity of Unbounded Dependency Constructions*. Stanford, CA: CSLI Publications.
- Müller, S. (1999). An HPSG-analysis for free relative clauses in German. *Grammars*, 2(1), 53–105.
- Ouhalla, J. (2004). Semitic relatives. *Linguistic Inquiry*, 35(2), 288–300.
- Ross, J. (1967). *Constraints on Variables in Syntax*. Doctoral dissertation, MIT, Cambridge, Mass.
- Taghvaipour, M. (2004). An HPSG analysis of Persian relative clauses. In S. Müller (ed.), *Proceedings of the 11th International Conference on Head-Driven Phrase Structure Grammar, Center for Computational Linguistics, Katholieke Universiteit Leuven*, Stanford, CA: CSLI Publications, 274–293.

- Taghvaipour, M. (2005). Persian free relatives. In S. Müller (ed.), *Proceedings of the 12th International Conference on Head-Driven Phrase Structure Grammar, Department of Informatics, University of Lisbon*, Stanford,CA: CSLI Publications, 364–374.
- Vaillette, N. (2000), Hebrew relative clauses in HPSG, in D. Flickinger and A. Kathol (eds.), *Proceedings of the International Conference on Head-Driven Phrase Structure Grammar*, Stanford, CA: CSLI Publications, 305–324.
- Wright, A., & Kathol, A. (2003). When a head is not a head: A constructional approach to exocentricity in English. In J-B. Kim and S. Wechsler (eds.) *Proceedings of the 9th International Conference on Head-Driven Phrase Structure Grammar*, Stanford University, 373–389.